

School				Mark (10)
Name		HKID		
Class (No.)		Date		

## B1 Young Modulus of Copper

### Answers to Preview Questions

1. \_\_\_\_\_
2. \_\_\_\_\_
3. \_\_\_\_\_
4. \_\_\_\_\_

### Experiment 1 Studying the stress-strain behaviour of a copper wire

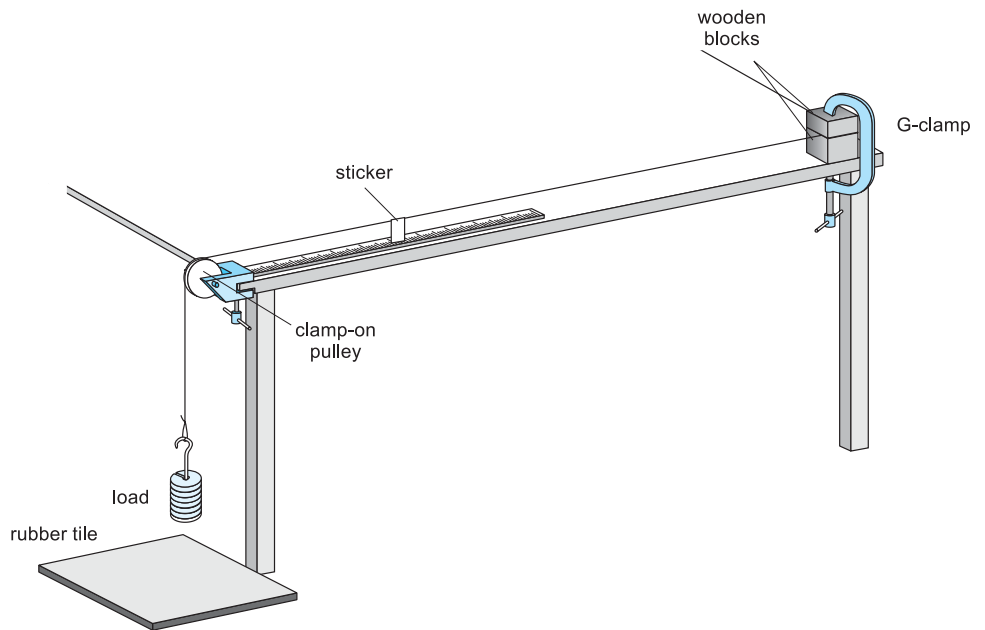

Experiment 1

#### Experiment 1 Step 1

Table 1

d1	d2	d3	d4	Mean

Cross-sectional area = \_\_\_\_\_

#### Experiment 1 Step 6

Natural length = \_\_\_\_\_

Plot of stress against strain (Experiment 1)

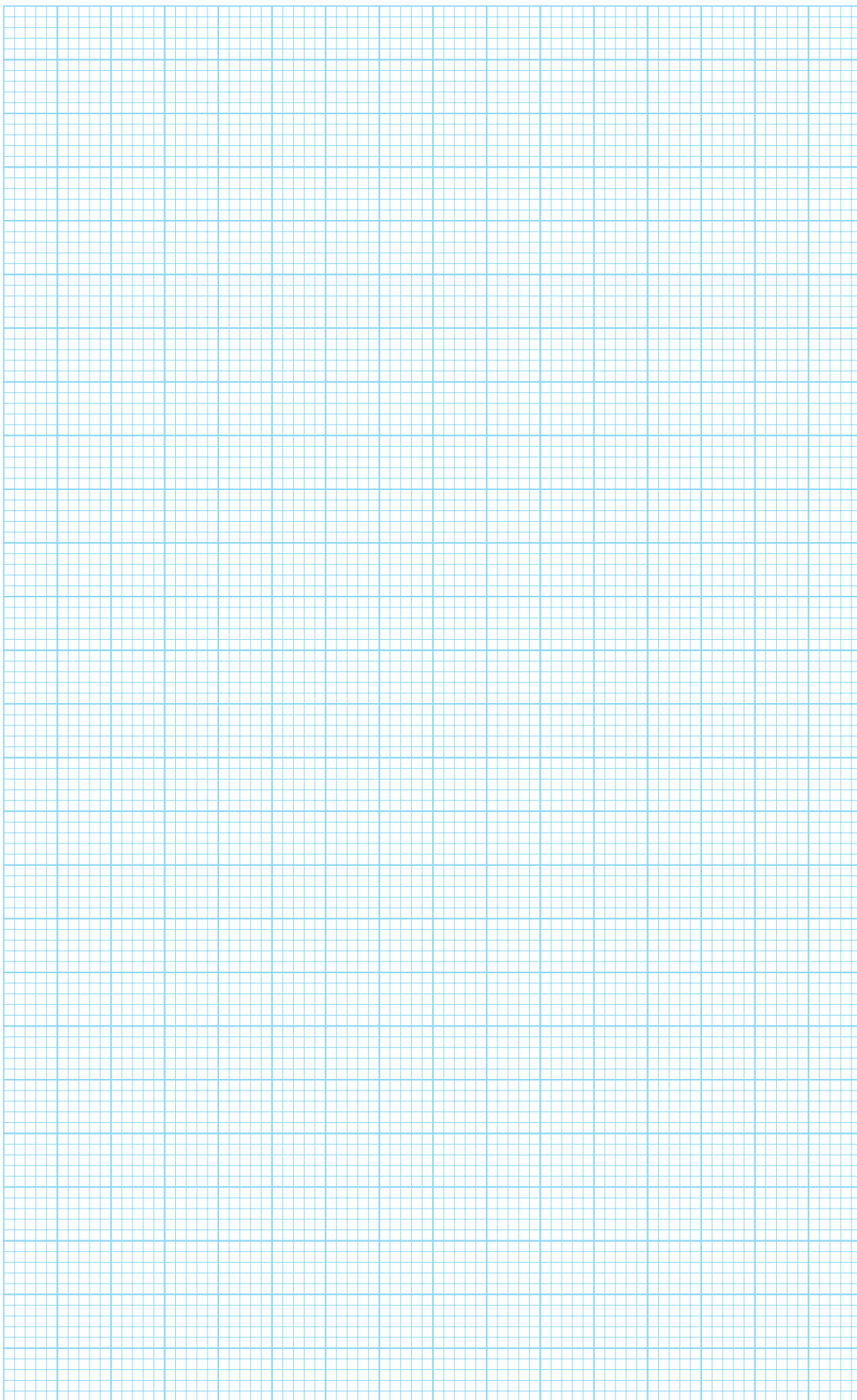

Teacher's Remark

Table 2

Load ( )	
Extension ( )	
Stress ( )	
Strain	

Load ( )	
Extension ( )	
Stress ( )	
Strain	

**Data Analysis 1**

- 3. Stress at elastic limit \_\_\_\_\_  
Maximum load for elastic deformation \_\_\_\_\_
- 5. Load for breaking the wire \_\_\_\_\_  
Breaking stress \_\_\_\_\_

*Stick the broken section of the copper wire here.*

**Experiment 2 Elastic deformation and Young modulus**

Table 3

Load ( )	
Extension ( )	
Stress ( )	
Strain	

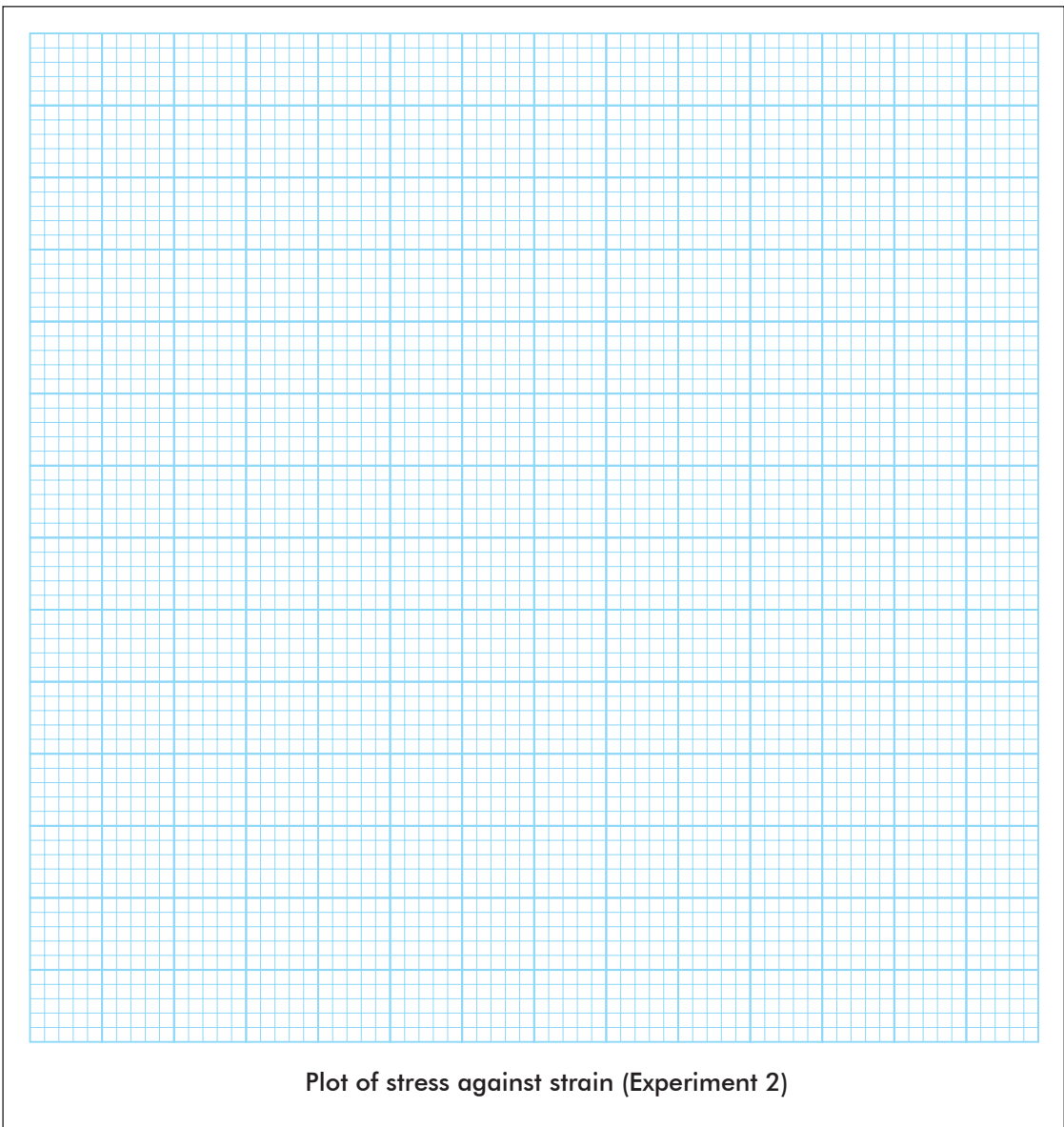

**Experiment 2 Step 2**

Does the wire return to the original length each time? \_\_\_\_\_

If not, state the range of load that causes permanent extension \_\_\_\_\_

**Experiment 2 Step 3**

Maximum load for elastic deformation \_\_\_\_\_

**Data Analysis 2**

3. Slope of the best-fit line,  $m$  \_\_\_\_\_

Young modulus of copper \_\_\_\_\_

4.3 Maximum slope  $m^+$  \_\_\_\_\_

Minimum slope  $m^-$  \_\_\_\_\_

4.4 Maximum deviation in slope \_\_\_\_\_

4.5 Percent error in slope \_\_\_\_\_

Percent error in Young modulus \_\_\_\_\_

Teacher's Remark

**Experiment 3 Breaking stress and physical dimension**

**Experiment 3 Step 1**

Natural length = \_\_\_\_\_

**Experiment 3 Step 2**

Load for breaking the wire \_\_\_\_\_

Breaking stress \_\_\_\_\_

**Experiment 3 Step 3**

Compare breaking stress with Experiment 1 \_\_\_\_\_

Percent difference \_\_\_\_\_

Conclusion \_\_\_\_\_

**Experiment 3 Step 4**

Table 4

d1	d2	d3	d4	Mean

Cross-sectional area \_\_\_\_\_

Natural length = \_\_\_\_\_

**Experiment 3 Step 5**

Load for breaking the wire \_\_\_\_\_

Breaking stress \_\_\_\_\_

**Experiment 3 Step 6**

Compare breaking stress with Experiment 1 \_\_\_\_\_

Percent difference \_\_\_\_\_

Conclusion \_\_\_\_\_

**Answers to Discussion**

Teacher's Remark

1. \_\_\_\_\_  
\_\_\_\_\_  
\_\_\_\_\_  
\_\_\_\_\_
2. \_\_\_\_\_  
\_\_\_\_\_  
\_\_\_\_\_  
\_\_\_\_\_
3. \_\_\_\_\_  
\_\_\_\_\_  
\_\_\_\_\_  
\_\_\_\_\_  
\_\_\_\_\_
4. \_\_\_\_\_  
\_\_\_\_\_  
\_\_\_\_\_  
\_\_\_\_\_  
\_\_\_\_\_  
\_\_\_\_\_